



SANOVO 
TECHNOLOGY GROUP

Höckerstapler SX20

Der wirtschaftliche Stapler für
Ihren Farmpacker!



Schropper

Verpackungsausrüstung optimiert auf Ihre Bedürfnisse



FARMPACKER 40

14.400 Eier/Stunde

40 Kisten/Stunde



FARMPACKER 70

25.200 Eier/Stunde

70 Kisten/Stunde



FARMPACKER 100

36.000 Eier/Stunde

100 Kisten/Stunde



FARMPACKER 200

72.000 Eier/Stunde

200 Kisten/Stunde



FARMPACKER 24000

24.000 Eier/Stunde

67 Kisten/Stunde



Höckerstapler SX20

SANOVO Höckerstapler SX20

TECHNOLOGY GROUP

Sehr wirtschaftlich & sehr platzsparend



Einfaches Umschalten

Ein- und Ausschalten mit nur einer Taste zur Bedienung des SX20

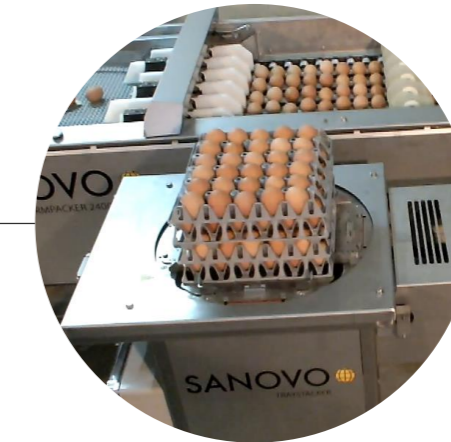

Ergonomisches Stapeln

Der Höcker erreicht die perfekte Aufnahmehöhe bei minimaler Belastung des Rückens des Bedieners



Design

Ausgeführt in Edelstahl ist der SX20 ein robuster Bestandteil Ihres Verpackungsvorgangs

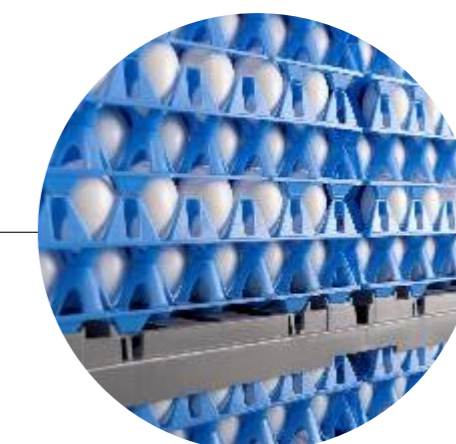

Anpassungsfähigkeit

Der SX20 kann mit fast jeder Art von 30er Kunststoffhöcker befüllt werden. Wir empfehlen ECS® von GI-OVO.

Mögliche Layouts

SANOVO  SFP40 mit Höckerstapler **SX20**
TECHNOLOGY GROUP

FP 40 inkl. SX20

€ 28.700,- exkl. USt.

SX20

€ 7.500,- exkl. USt

SFP40A1SX20

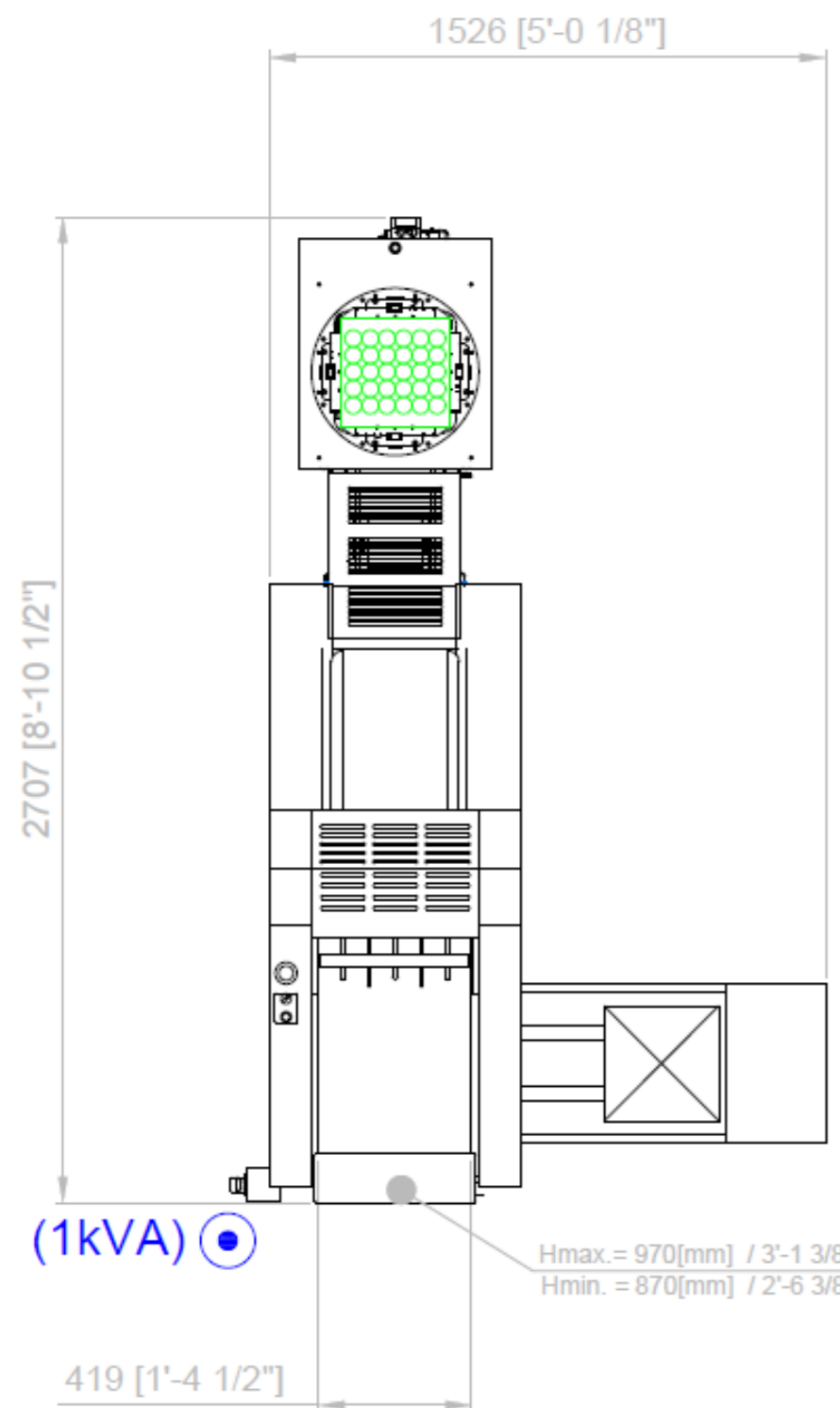

SFP40A2SX20

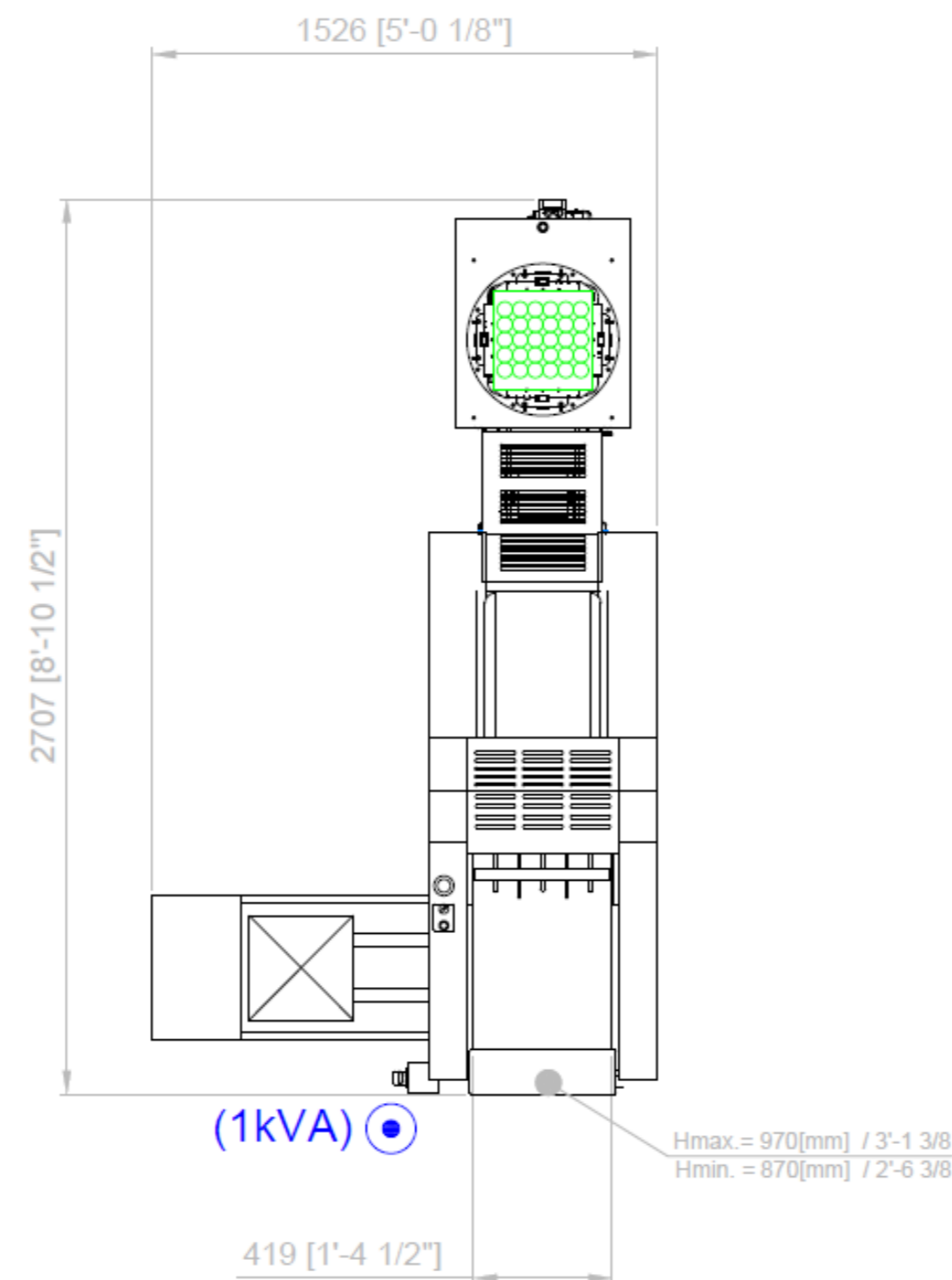

SFP40A3SX20

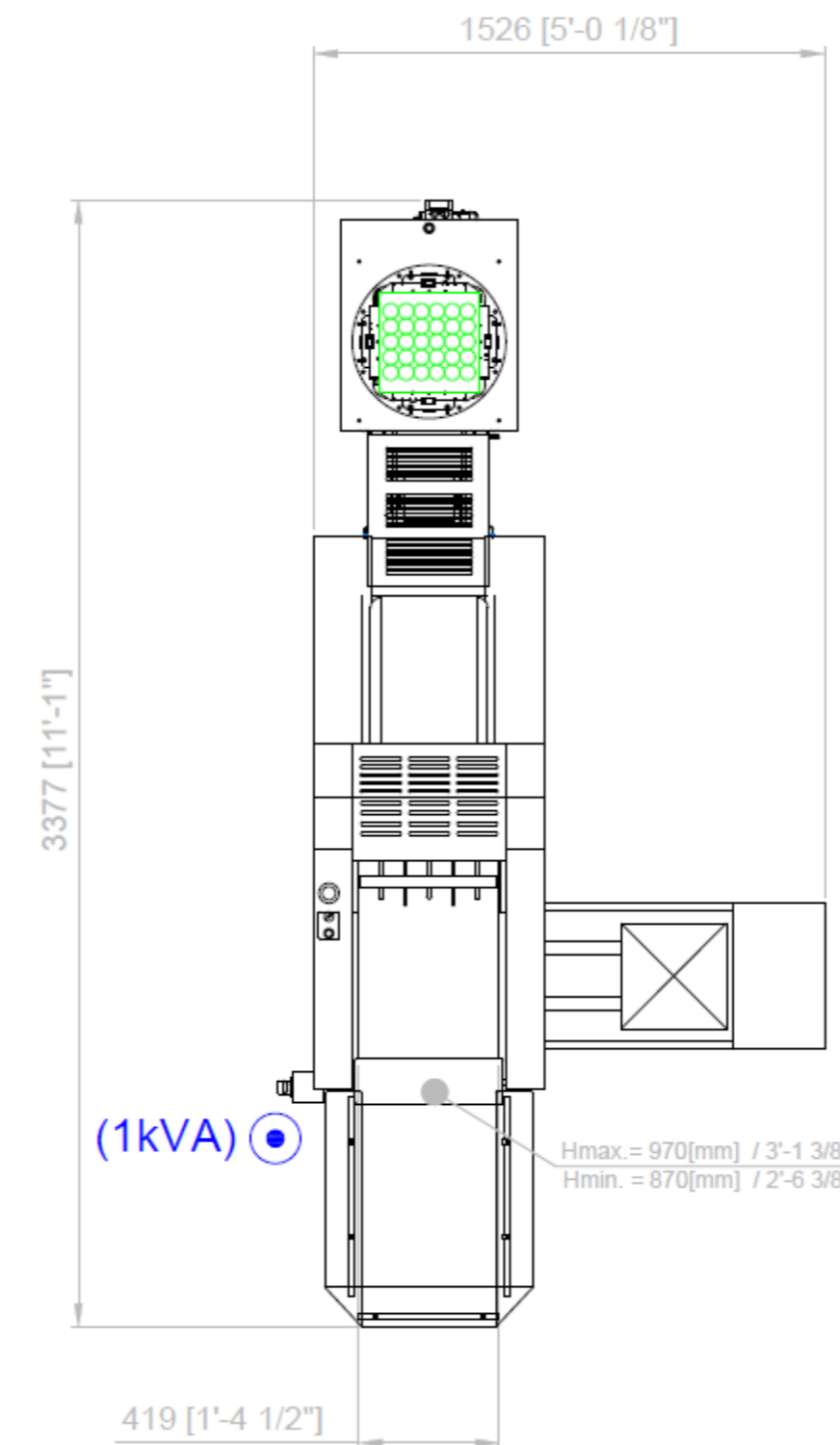

SFP40A4SX20

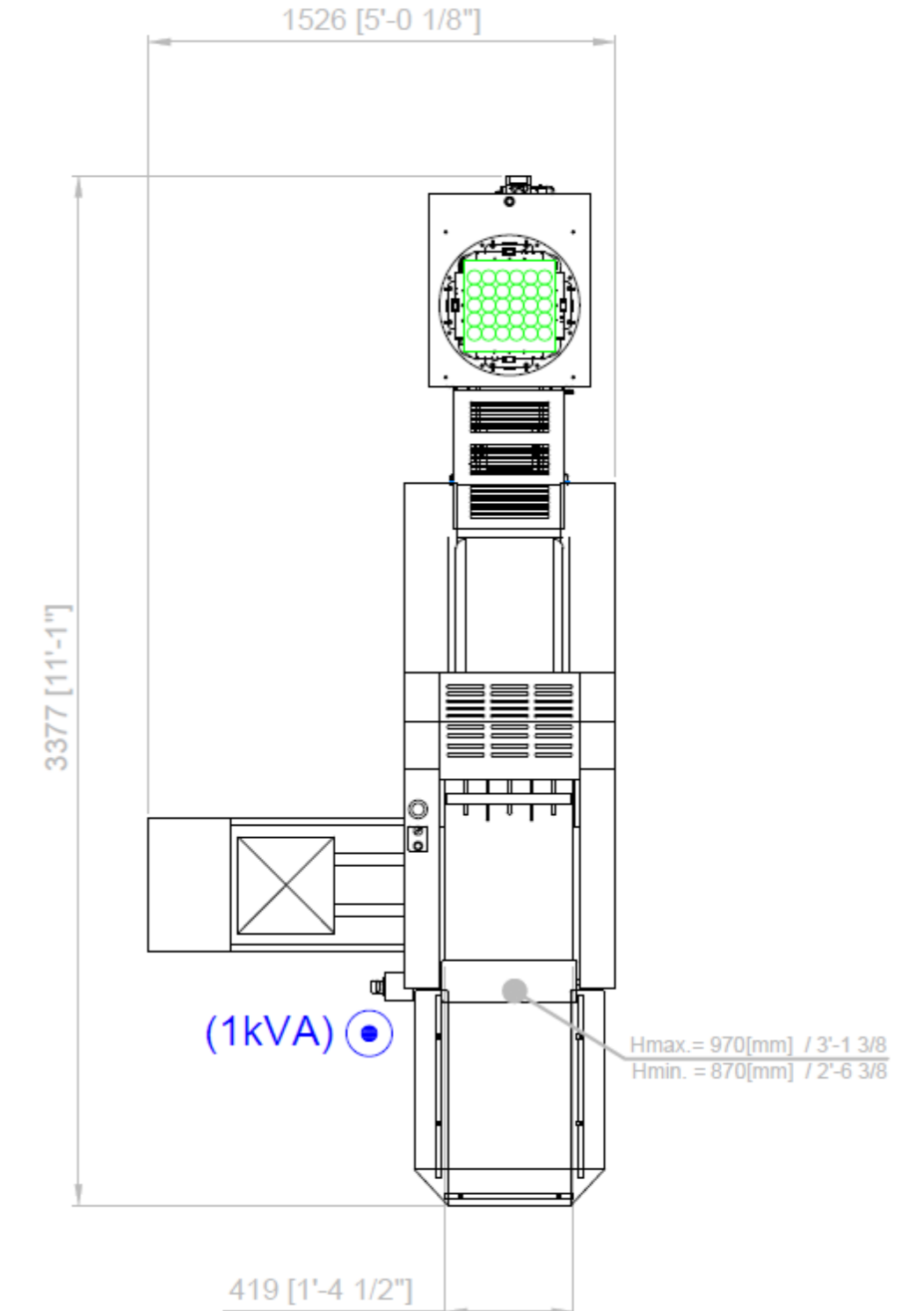

Mögliche Layouts

SANOVO  SFP70 mit Höckerstapler SX20
TECHNOLOGY GROUP

SFP70A1SX20

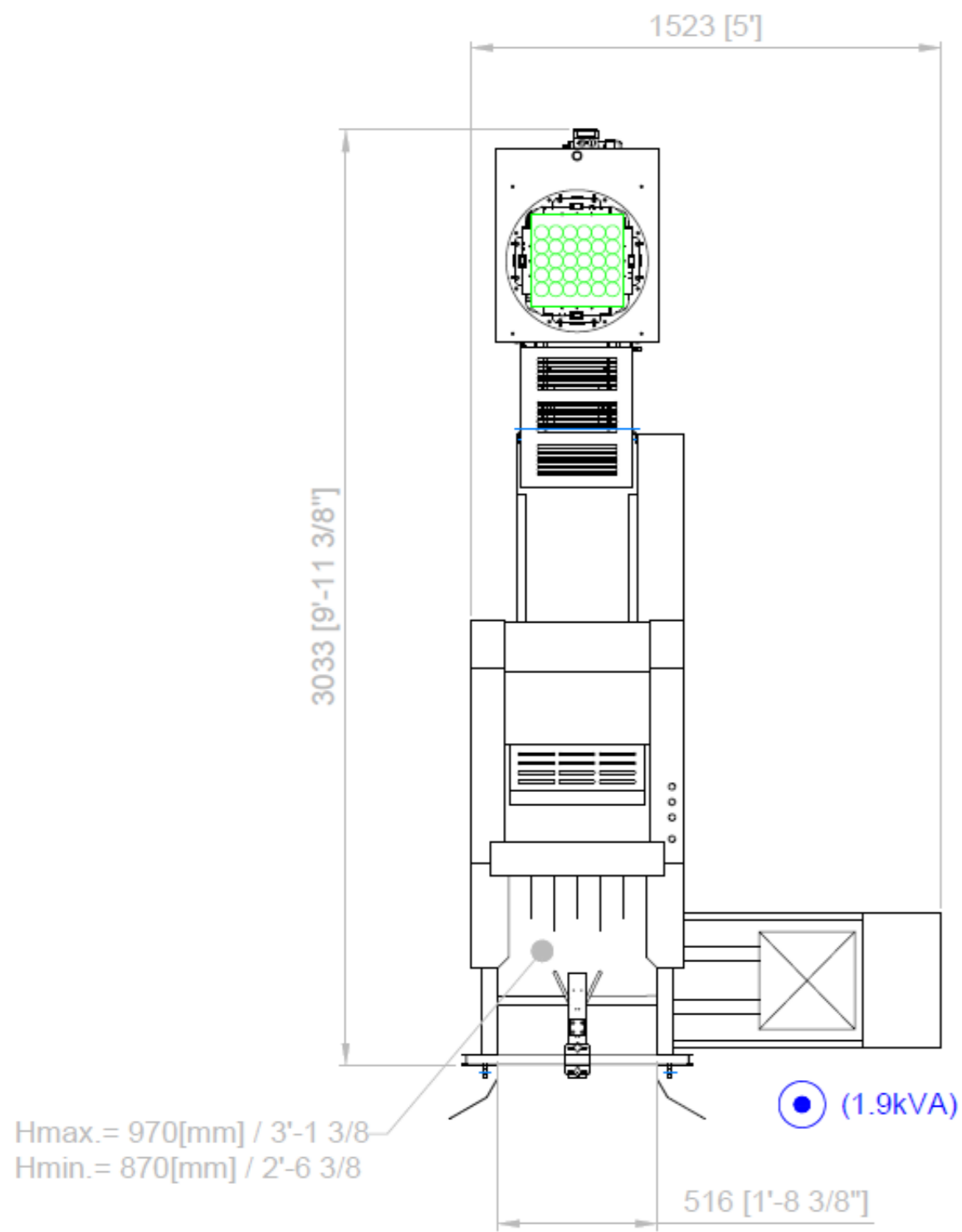

SFP70A2SX20

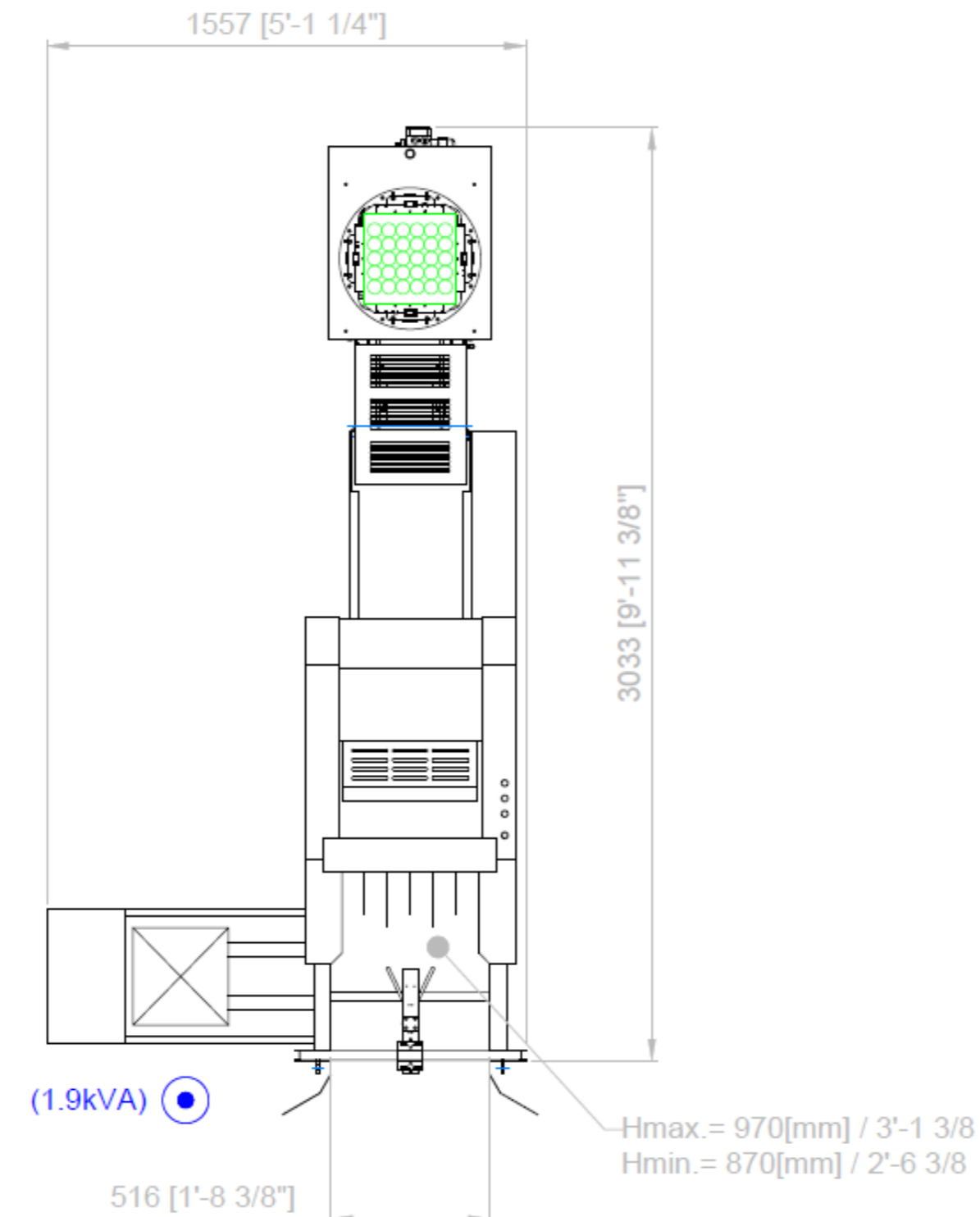

SFP70A3SX20

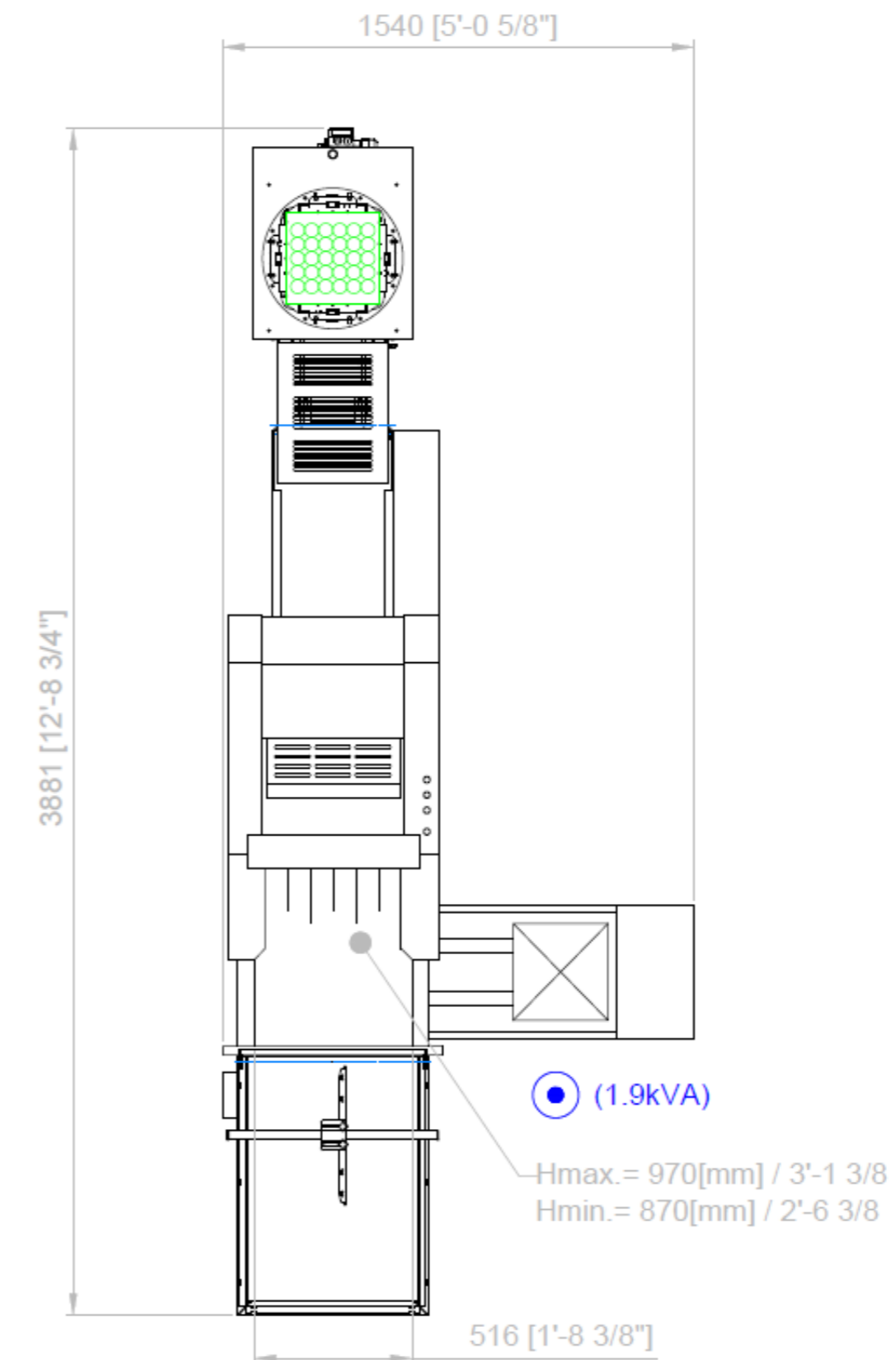

SFP70A4SX20

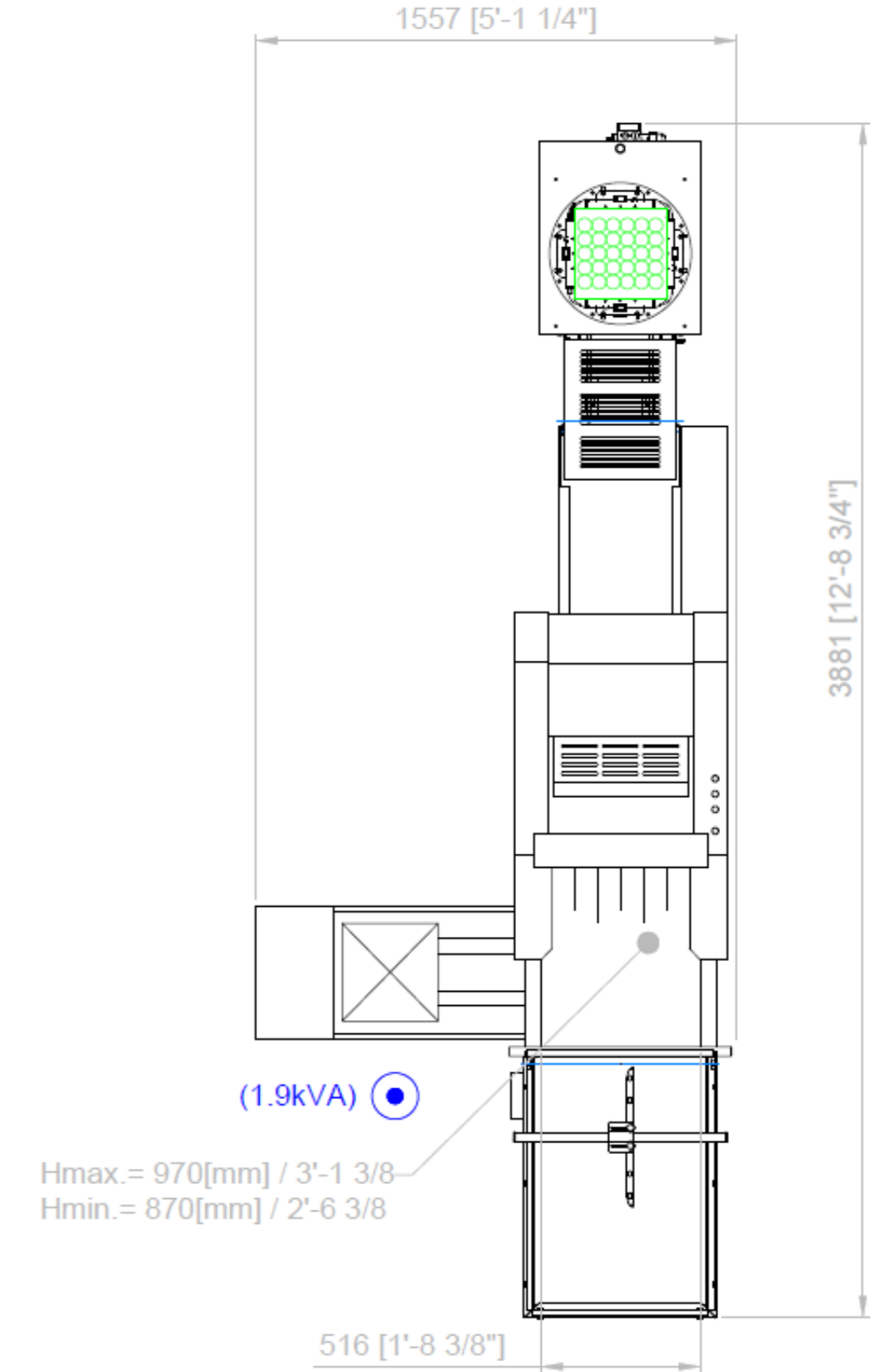

Mögliche Layouts

SANOVO TECHNOLOGY GROUP SFP24000 mit Höckerstapler SX20

SFP24000A1SX20

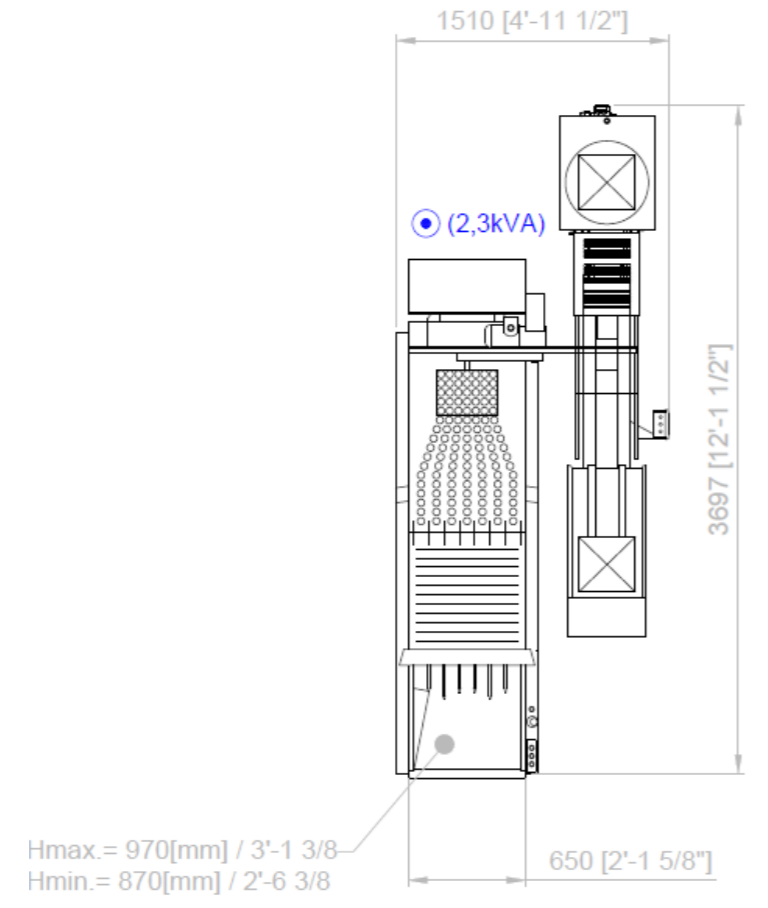

SFP24000A2SX20

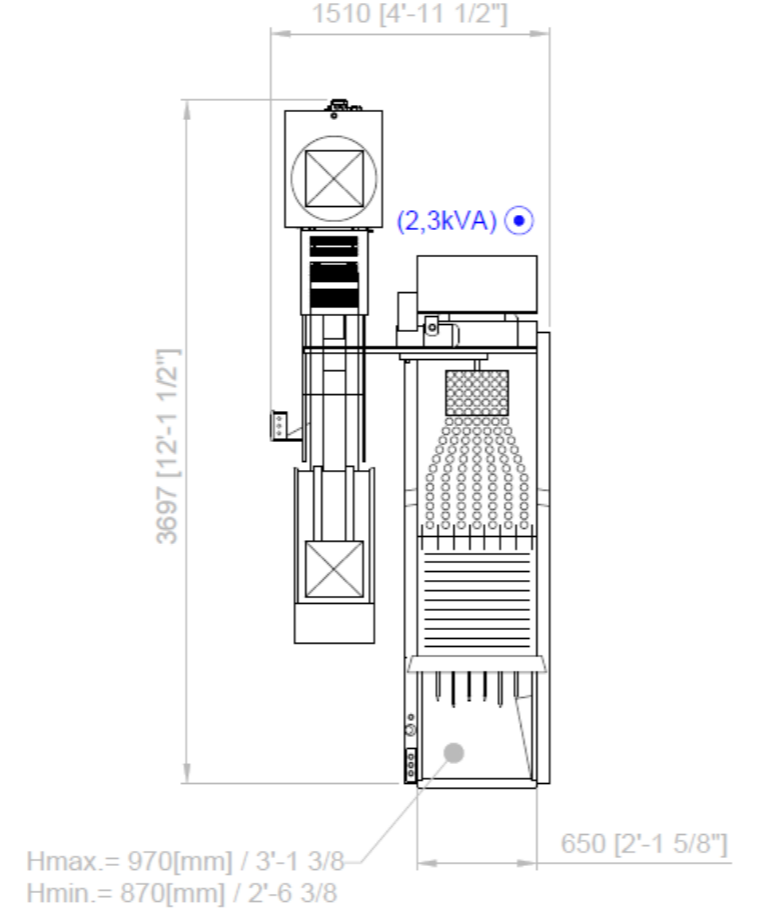

SFP24000A3SX20

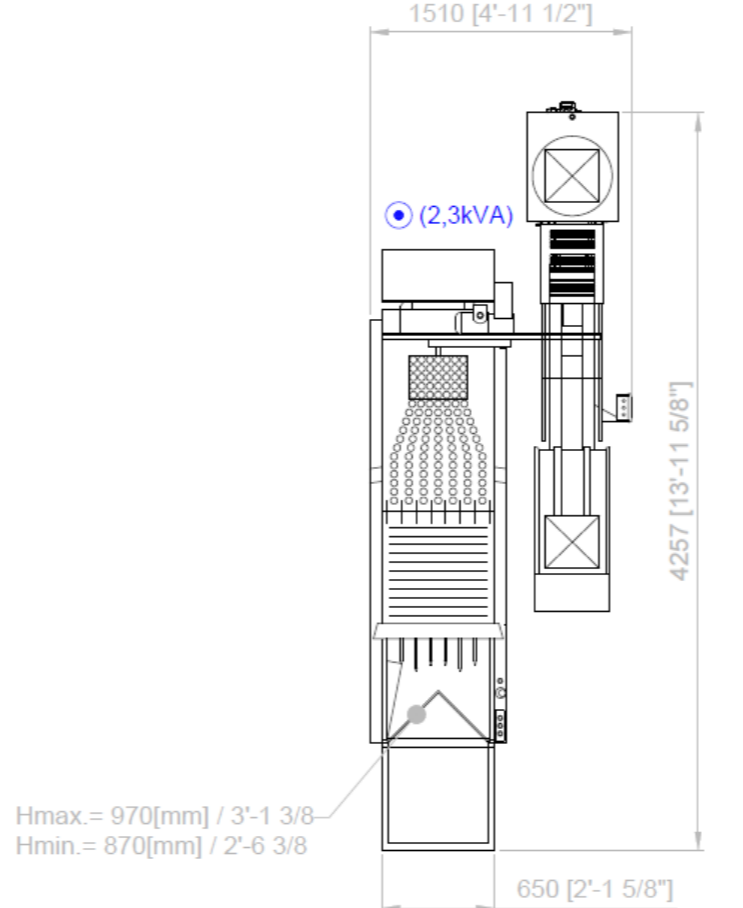

SFP24000A4SX20

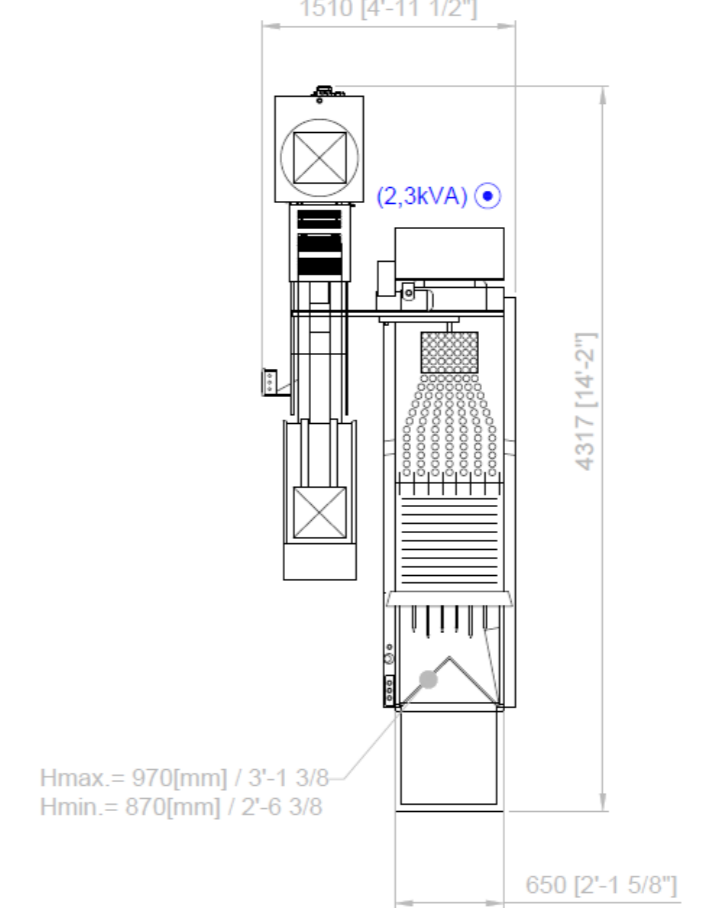

SFP24000B1SX20

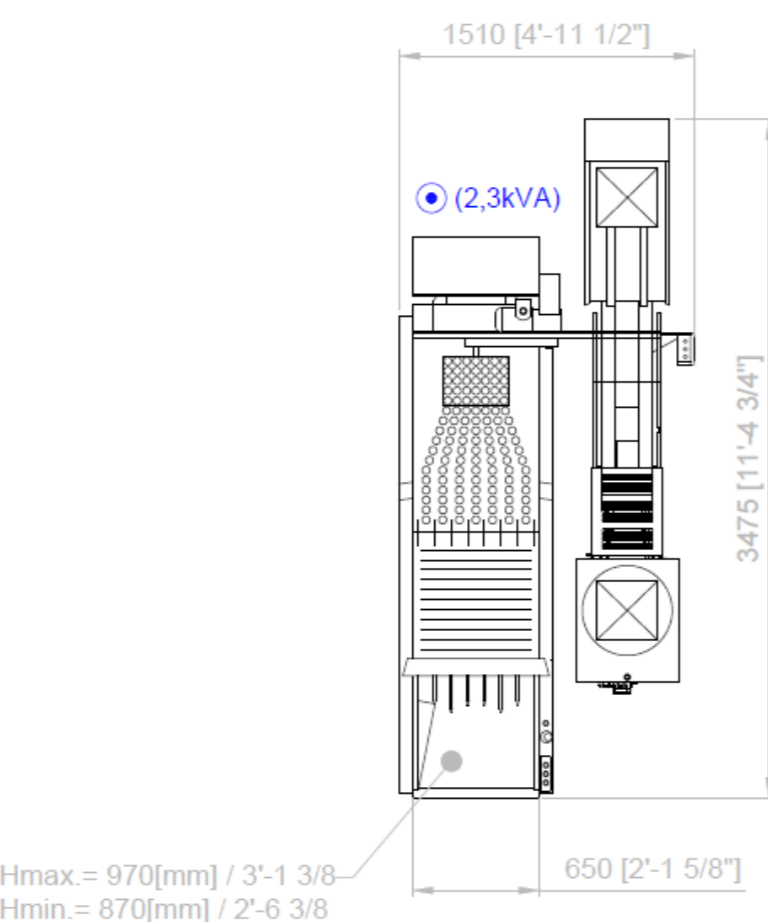

SFP24000B2SX20

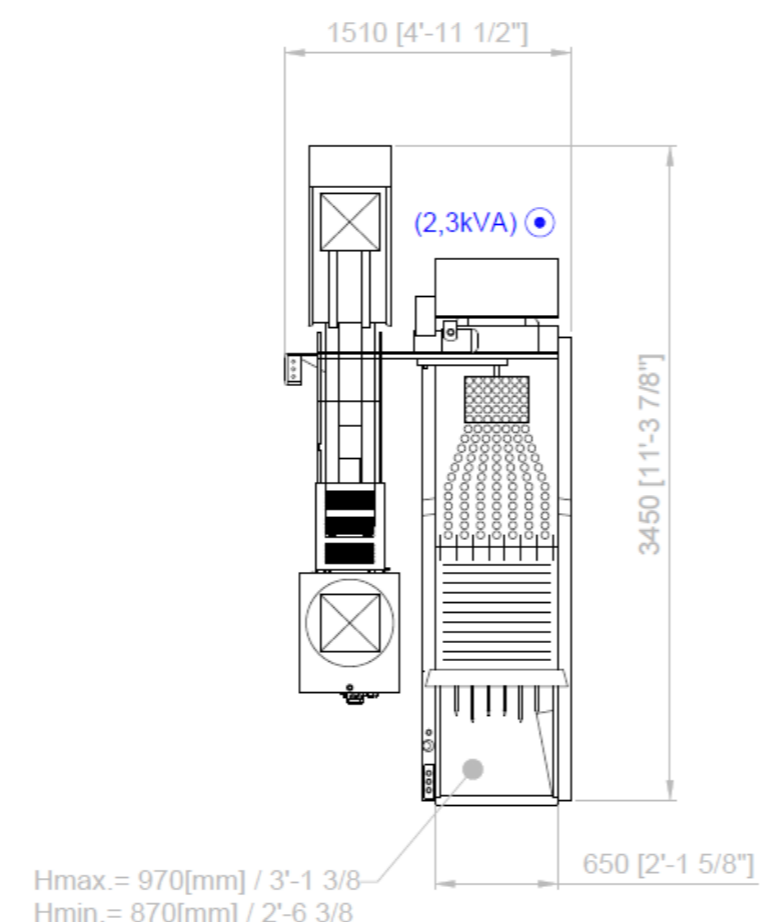

SFP24000B3SX20

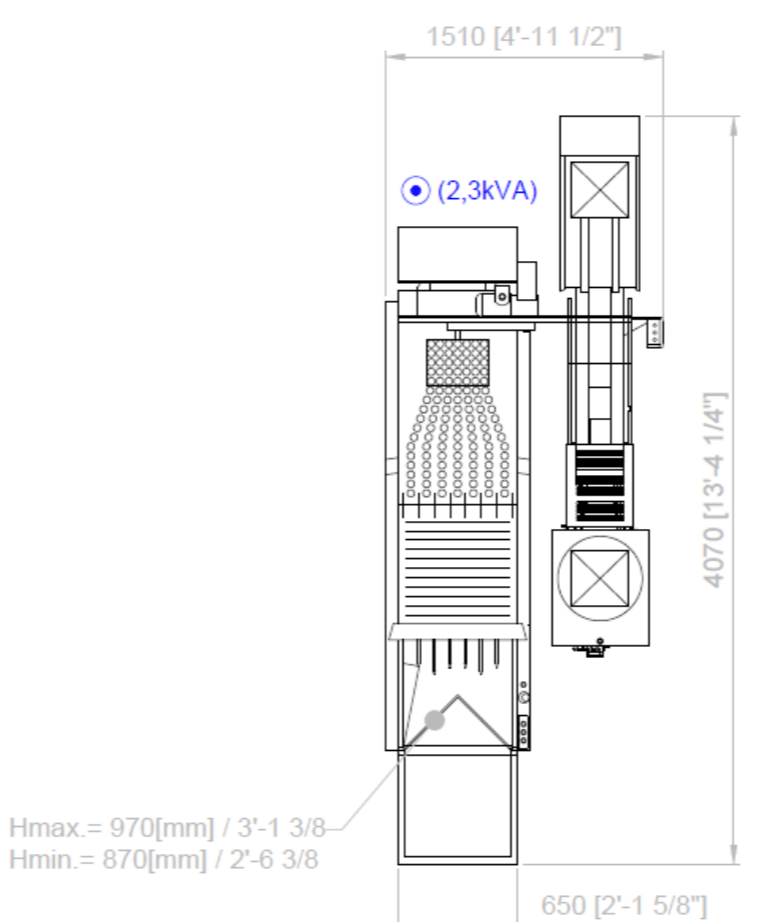

SFP24000B4SX20

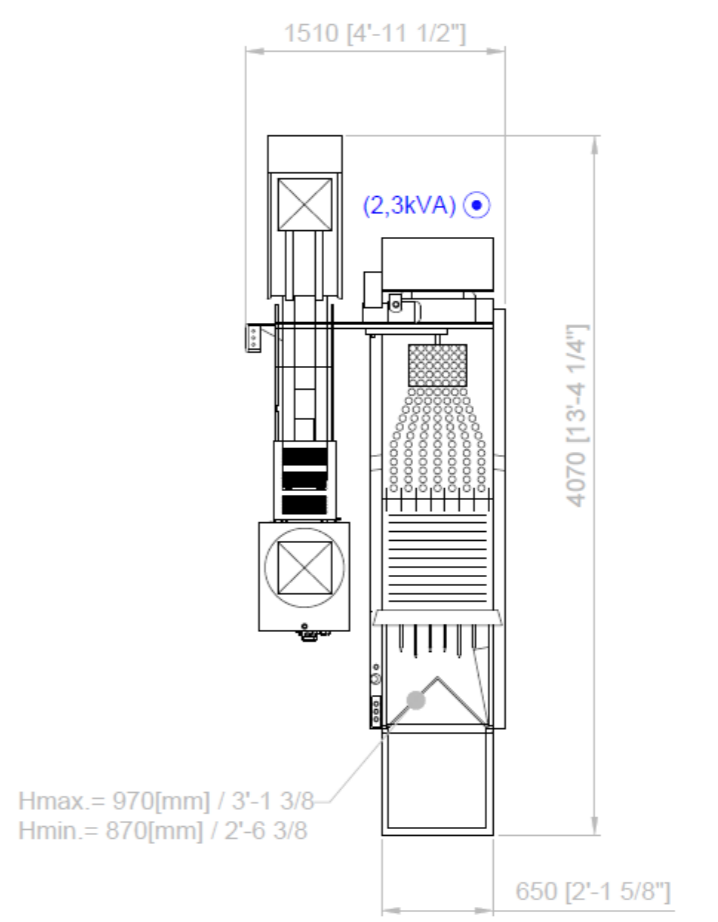

Datenblatt

SANOVO TECHNOLOGY GROUP **Höckerstapler SX20**

Hauptmerkmale

- Geringer Platzbedarf
- Edelstahl Ausführung
- Einfache Bedienung
- Ergonomisches Design
- Niedriger Energieverbrauch
- Für bestehende Maschinen
- Nur für Kunststoffhöcker



SANOVO Höckerstapler SX20



EggsCargoSystem® by GI-OVO

Technische Spezifikationen

- Einphasig 230VAC, 0.7kVA
- Länge: 1.160 mm
- Breite: 526 mm
- Fläche: 0,6 m²